



ARCHITECTURAL METALS, INC.

***2" x 4-1/2" SERIES 2000
STOREFRONT INSTALLATION
& GLAZING MANUAL***

Note: Installation and Glazing Manuals are product specific.

FOR REVIEW ONLY

2000 INSTALLATION MANUAL

INFORMATION

All framing members shown in this section, unless noted otherwise, are stock items in Dark Bronze or Clear anodic coating, and are available for prompt shipment. Other anodic coatings or painted finishes are also available upon inquiry.

SPECIFICATIONS

I. GENERAL :

DESCRIPTION

Work included: Furnish all necessary materials, labor and equipment for the complete installation of aluminum framing as shown on the drawings and specified herein.

(Specifier Note: It is suggested that related items such as glass, sealants and aluminum entrances be included whenever possible.)

Work NOT included: Structural support of the framing system, interior closures, trim, metal sub-sills.

(Specifier list other exclusions).

Related Work Specified Elsewhere : (Specifier list)

QUALITY ASSURANCE:

Drawings and specifications are based upon the 2'' x 4-1/2'' Thermal Flush Glaze system as manufactured by Atlas Architectural Metals, Inc.. Whenever substitute products are to be considered, supporting technical literature, samples, drawings and performance data must be submitted in ten (10) days prior to bid in order to make a valid comparison of the products involved. Test reports certified by an independent testing laboratory must be made available upon request.

PERFORMANCE REQUIREMENTS:

Air infiltration shall be tested in accordance with ASTM E 283 infiltration shall not exceed 0.06 CFM per square foot of fixed area.

Water infiltration shall be tested in accordance with ASTM E 331.No water penetration at test pressure equal to 10% of the windload, but not less than 2.86 PSF. (AAMA 1.07.6.F)

Structural performance shall be used on:

*Maximum deflection to 1/175 of the span and...

*Allowable stress with a safety factor of 1.65.

The system shall perform to these criteria under a windload of (Specify) _____ PSF.



PHONE: 713-869-9551

Web Address: www.atlasarchmetals.com



2000 INSTALLATION MANUAL

INFORMATION

II. PRODUCTS :

MATERIALS

Extrusions shall be 6063-T5 alloy and temper (ASTM B221 alloy G.S.10A-T5). Fasteners, where exposed, shall be aluminum, stainless steel or zinc plated steel in accordance with ASTM A 164. Perimeter anchors shall be aluminum or steel, providing the steel is properly isolated from the aluminum. Glazing gaskets shall be EPDM or PVC extrusions. Single acting entrance frames shall include a pile weather-strip which will also provide a cushioning effect.

FINISH

All exposed framing surfaces shall be free of scratches and other serious blemishes. Aluminum extrusions will be given a caustic etch followed by an anodic oxide treatment to obtain... (Specify one of the following).

... an Architectural Dark Bronze Class 2 anodic coating with color conforming to Aluminum Association Standard AA-M10 C22 A31, 0.4 Mil thick.

... an Architectural 204-R1 anodic coating conforming to Aluminum Association Standard AA-M10 C22 A31, 0.4 Mil thick.

FABRICATION

The framing system shall provide for flush glazing on all sides with no projecting stops. Vertical and horizontal framing members shall have a nominal face dimension of 2". Overall depth shall be 4-1/2" with a 1.356" glass pocket width. Entrance framing members shall be compatible with glass framing in appearance.

III. EXECUTION :

INSTALLATION

All glass framing shall be set in correct locations as shown in the details and shall be level, square, plumb and in alignment with other work in accordance with the manufacturer's installation instructions and approved shop drawings. All joints between framing and the building structure shall be sealed in order to secure a watertight installation.

PROTECTION AND CLEANING

After installation, the General Contractor shall adequately protect exposed portions of aluminum surfaces from damage by grinding and polishing compounds, plaster, lime, acid, cement, or other contaminants. The General Contractor shall be responsible for final cleaning.



PHONE: 713-869-9551

Web Address: www.atlasarchmetals.com



2000 INSTALLATION MANUAL

FRAME FABRICATION

1.1 Establish frame size & cut metal to length.

Measure width of rough opening.

- A. Measure opening at bottom.
- B. Measure opening at center.
- C. Measure opening at top.

The frame width will be the smallest dimension less 1/2" allowing for a 1/4" caulk joint at each jamb.

Repeat process to determine frame height.

- A. Beginning on left side of opening, measure dimension from top to bottom.
- B. Repeat at center.
- C. Repeat at right side of opening.

The frame height will be the smallest dimension minus 3/4" to allow for subsill and a 1/4" caulk joint at the head and sill.

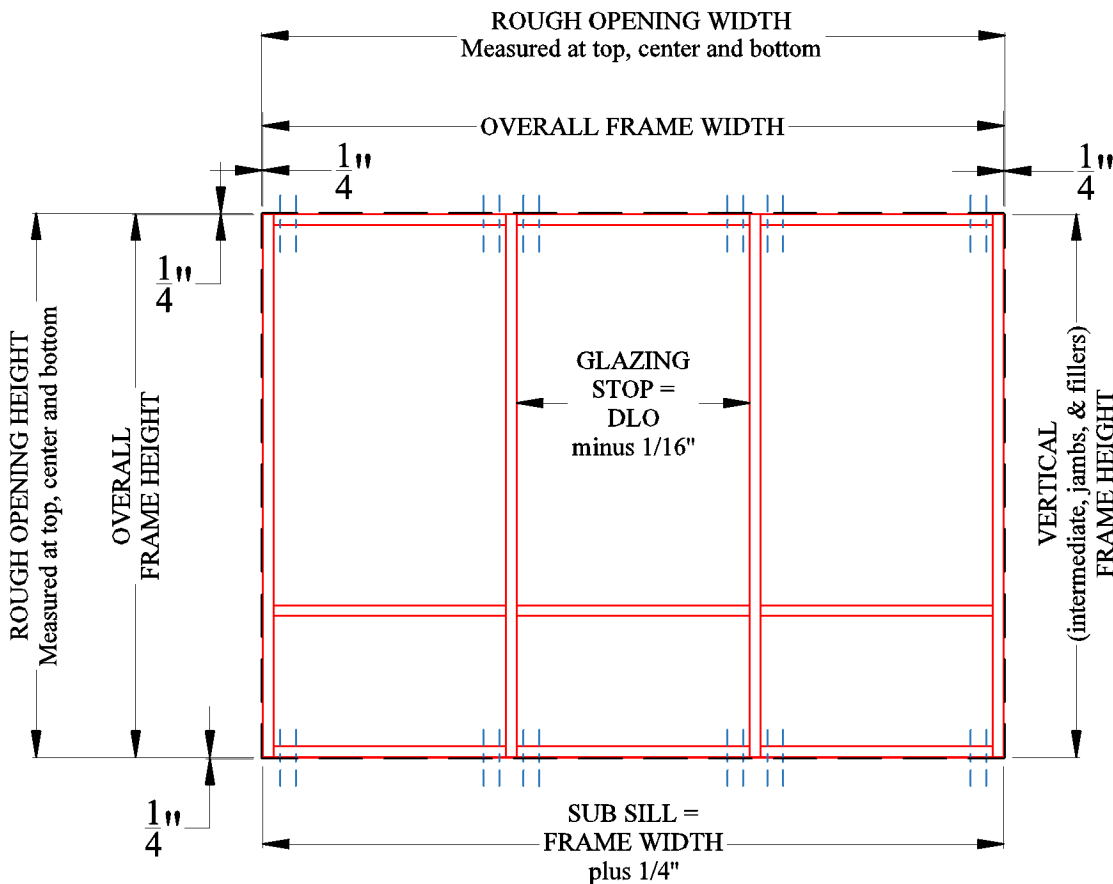

FIGURE 1.0
MOCK UP

ATLAS

ARCHITECTURAL METALS, INC.

PHONE: 713-869-9551

Web Address: www.atlasarchmetals.com

Made In

AMERICA

2000 INSTALLATION MANUAL

FRAME FABRICATION

1.2 Offset 1st hole location for End Dam at 1/2" center from ends.

1.3 Offset 1st anchor hole location at 1-1/2" center from ends, 2nd hole location at 4-1/2" center from first hole location. **SEE FIGURE 1.1**

Anchor size and frequency should be determined by structural requirements.

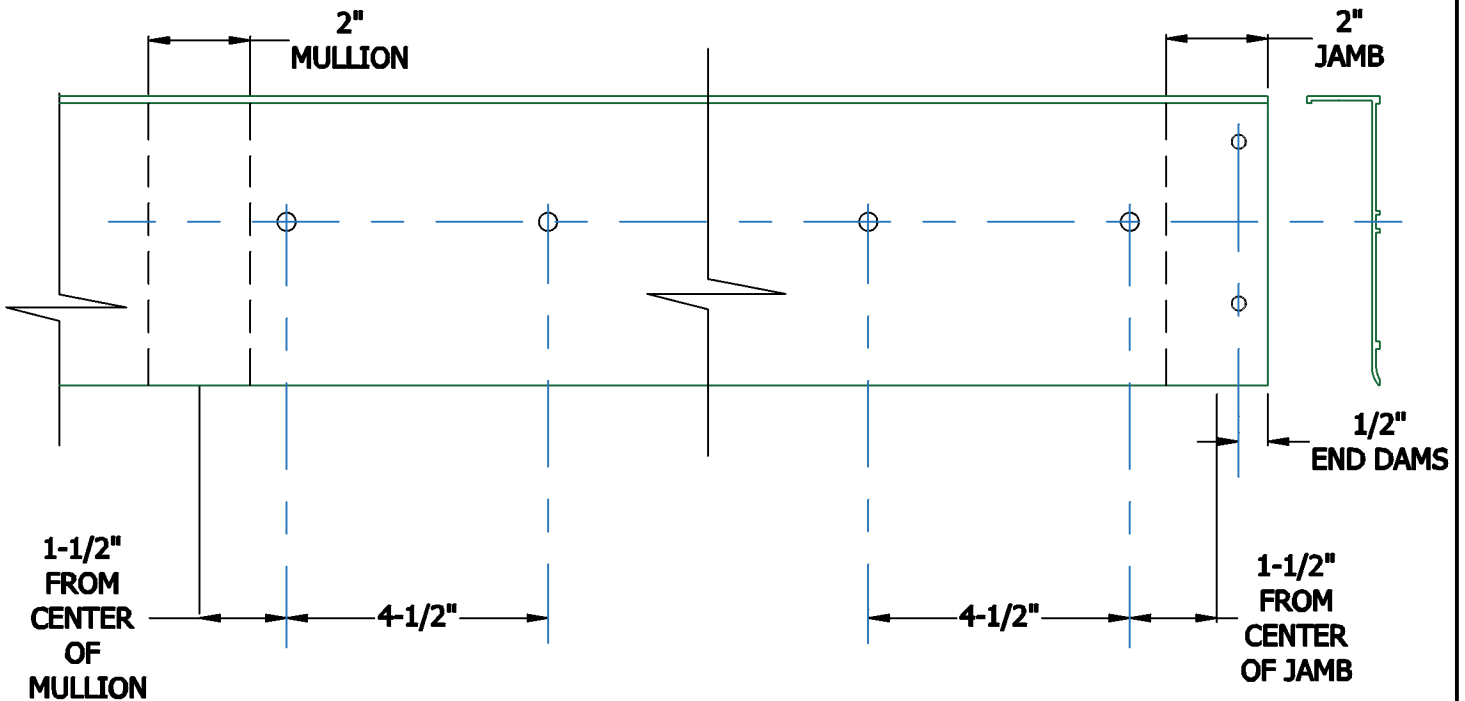
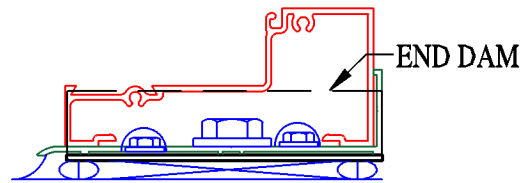

TYP. OFFSET FOR ANCHORS @
EACH MULLION CORNER AND JAMBS
SEE FIGURE 1.0

FIGURE 1.1
SILL FLASHING FABRICATION



ARCHITECTURAL METALS, INC.

PHONE: 713-869-9551

Web Address: www.atlasarchmetals.com

Made In



2000 INSTALLATION MANUAL

FRAME FABRICATION

1.4 Start first screw applied hole location for Filler at 2" center from bottom end. Continue hole location at 12" centers to the top. SEE FIGURE 1.2

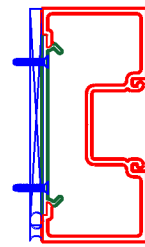
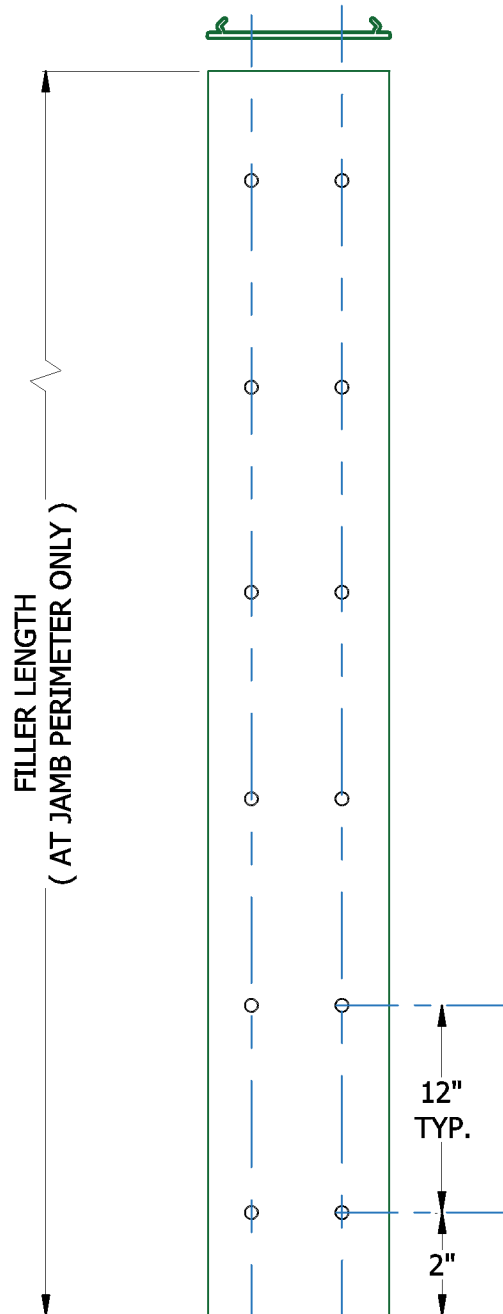

FIGURE 1.3
COMPOSITE

FIGURE 1.2
FILLER FABRICATION
(AT JAMB ONLY)

2000 INSTALLATION MANUAL

FRAME FABRICATION

1.5 Offset 1st anchor hole location at 1-1/2" center from ends, 2nd hole location at 4-1/2" center from first hole location. **SEE FIGURE 1.4**

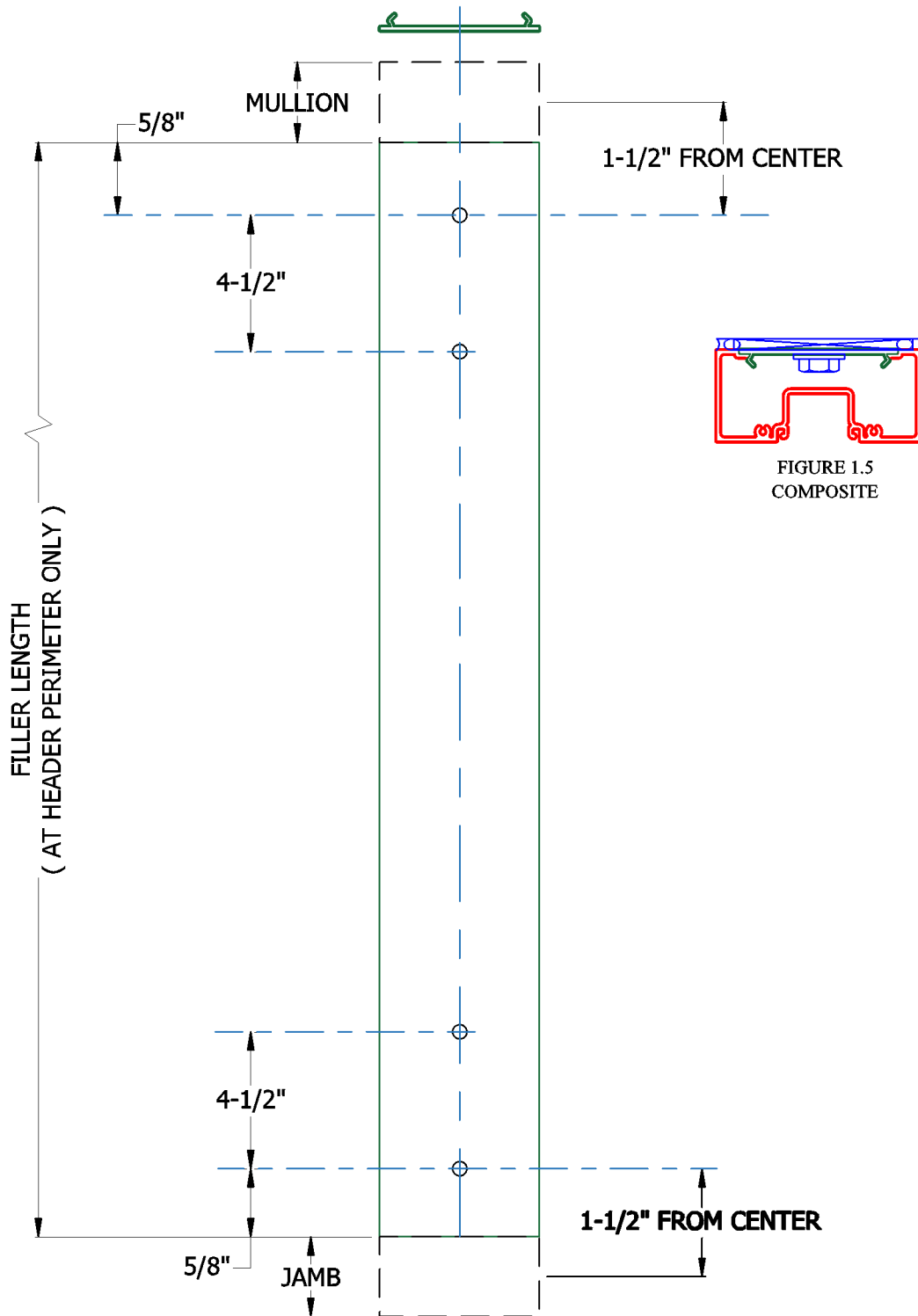

FIGURE 1.4
FILLER FABRICATION
(AT HEADER ONLY)

2000 INSTALLATION MANUAL

FRAME FABRICATION

1.6 Locate center of each hole according to where screw boss will be centered.

SEE FIGURE 1.6 & 1.7

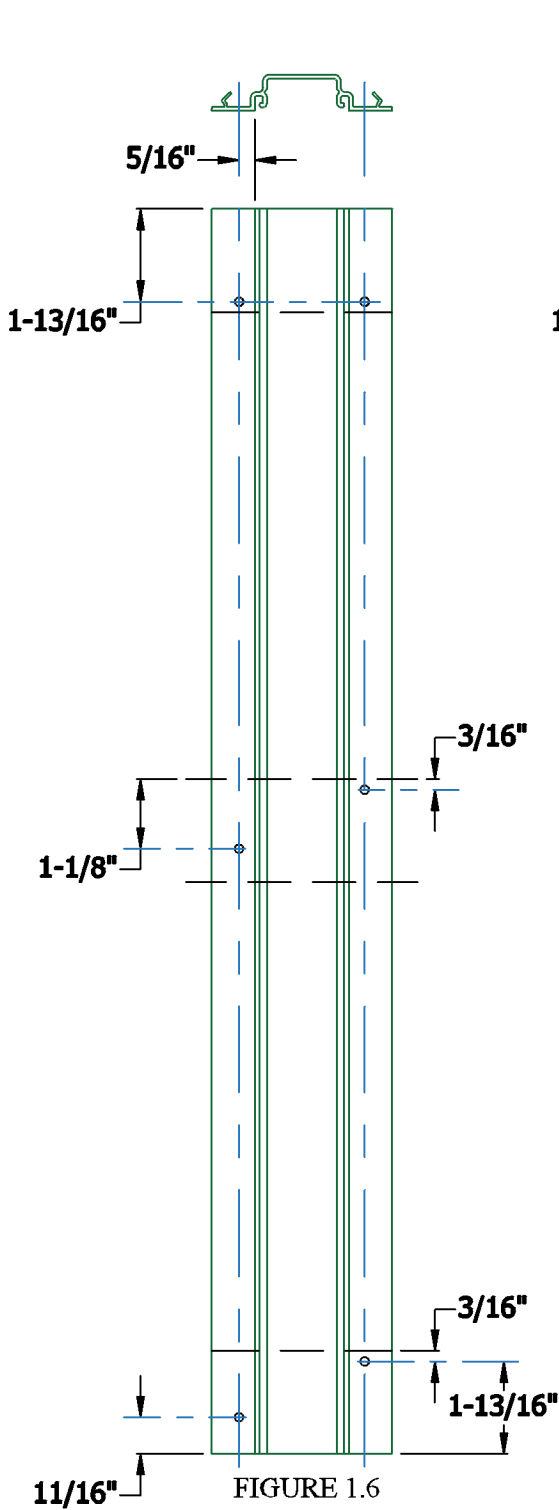

FIGURE 1.6
FILLER FABRICATION
(AT CENTER MULLIONS ONLY)

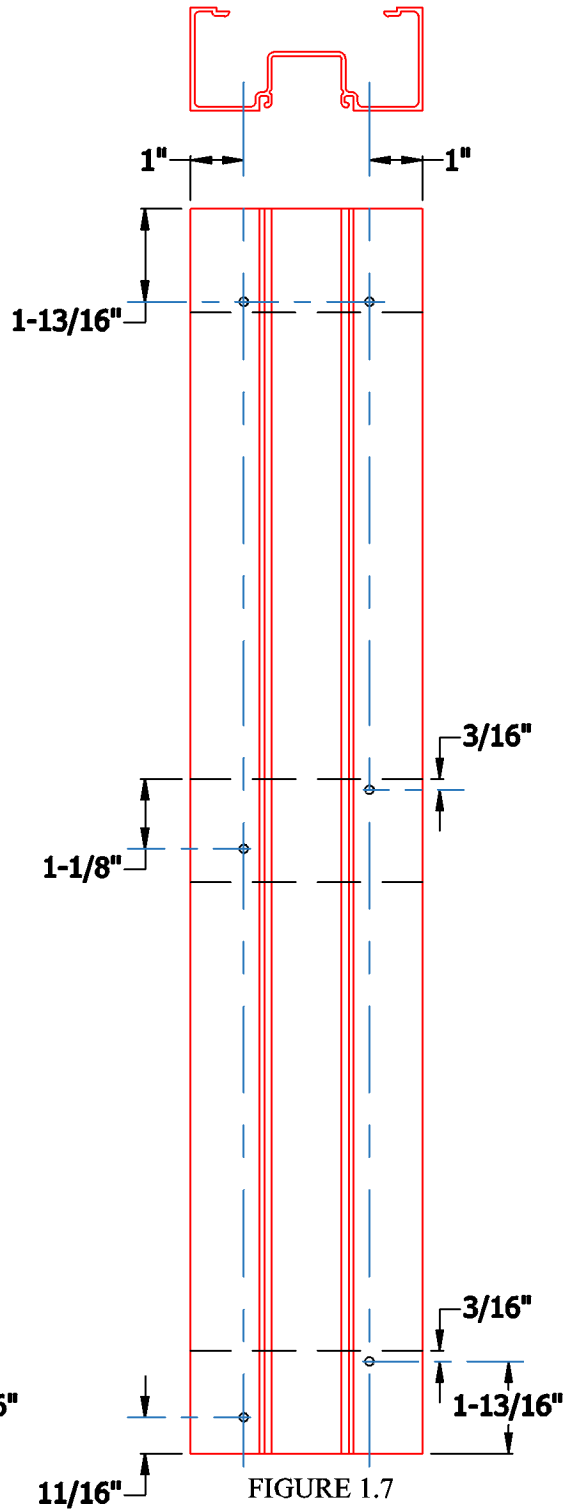
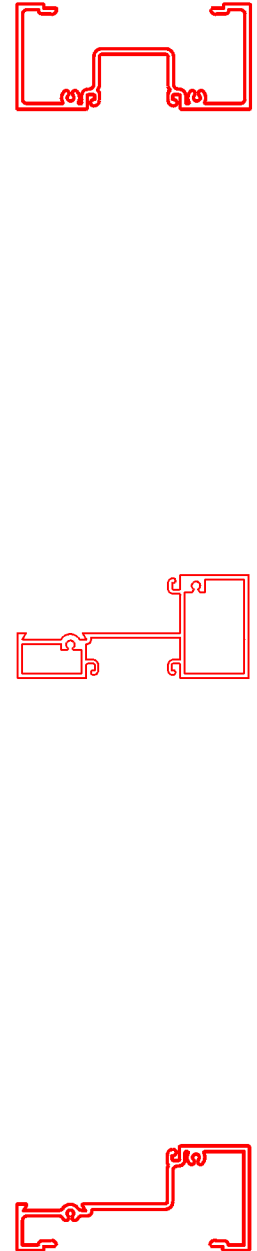

FIGURE 1.7
MULLION FABRICATION



2000 INSTALLATION MANUAL

FRAME ASSEMBLY

2.1 Install Sub Sill and End Dam, Sub Sill shall be installed level and should never tilt towards interior of building. DC-795 silicone shall be applied to installation. SEE FIGURE 2.0

Anchor size and frequency should be determined by structural requirements.

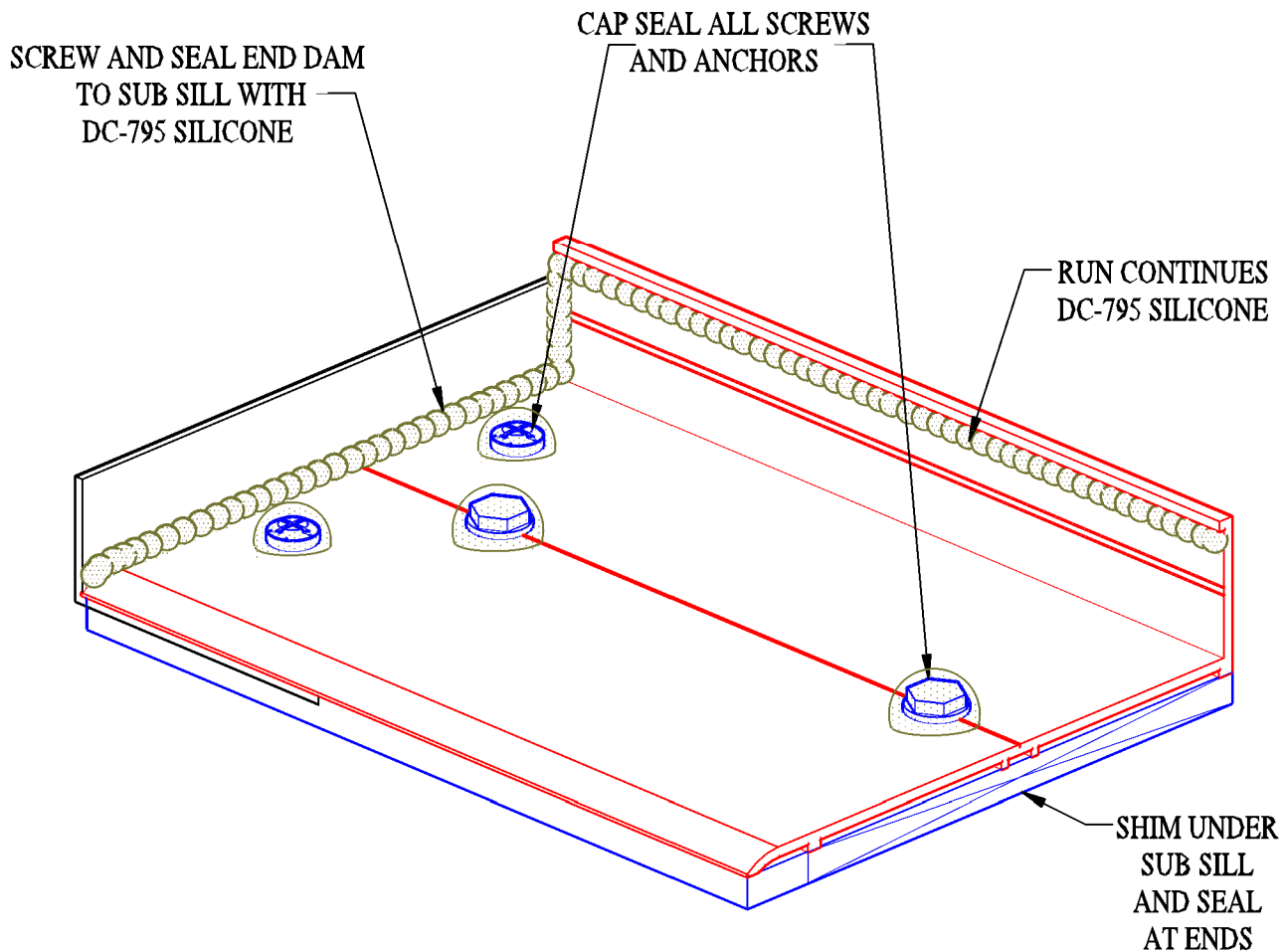

FIGURE 2.0
SILL FLASHING
INSTALLATION

2000 INSTALLATION MANUAL

FRAME ASSEMBLY

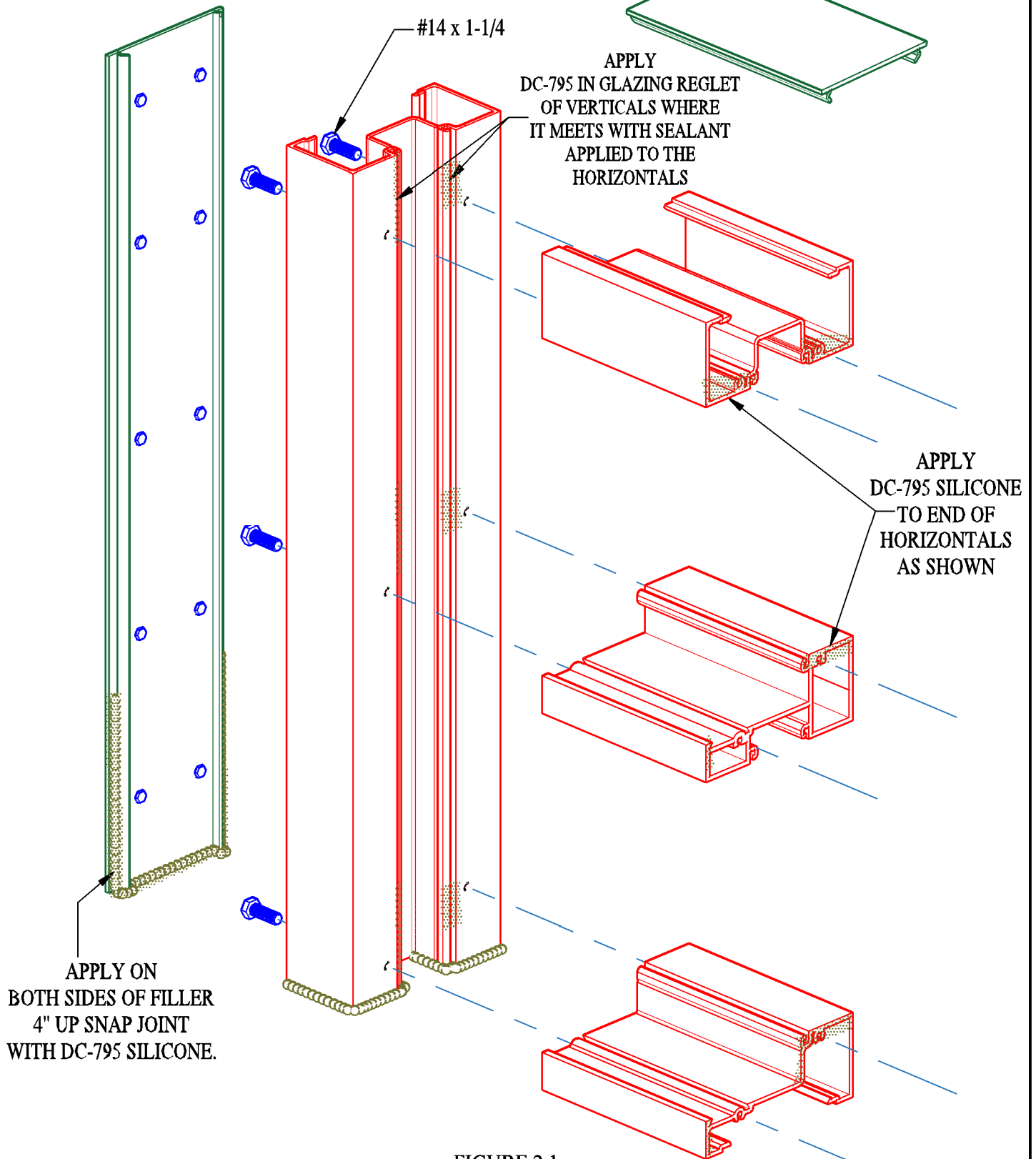

FIGURE 2.1
JAMB PERIMETER
INSTALLATION



ARCHITECTURAL METALS, INC.

PHONE: 713-869-9551

Web Address: www.atlasarchmetals.com

Made In

AMERICA

2000 INSTALLATION MANUAL

FRAME ASSEMBLY

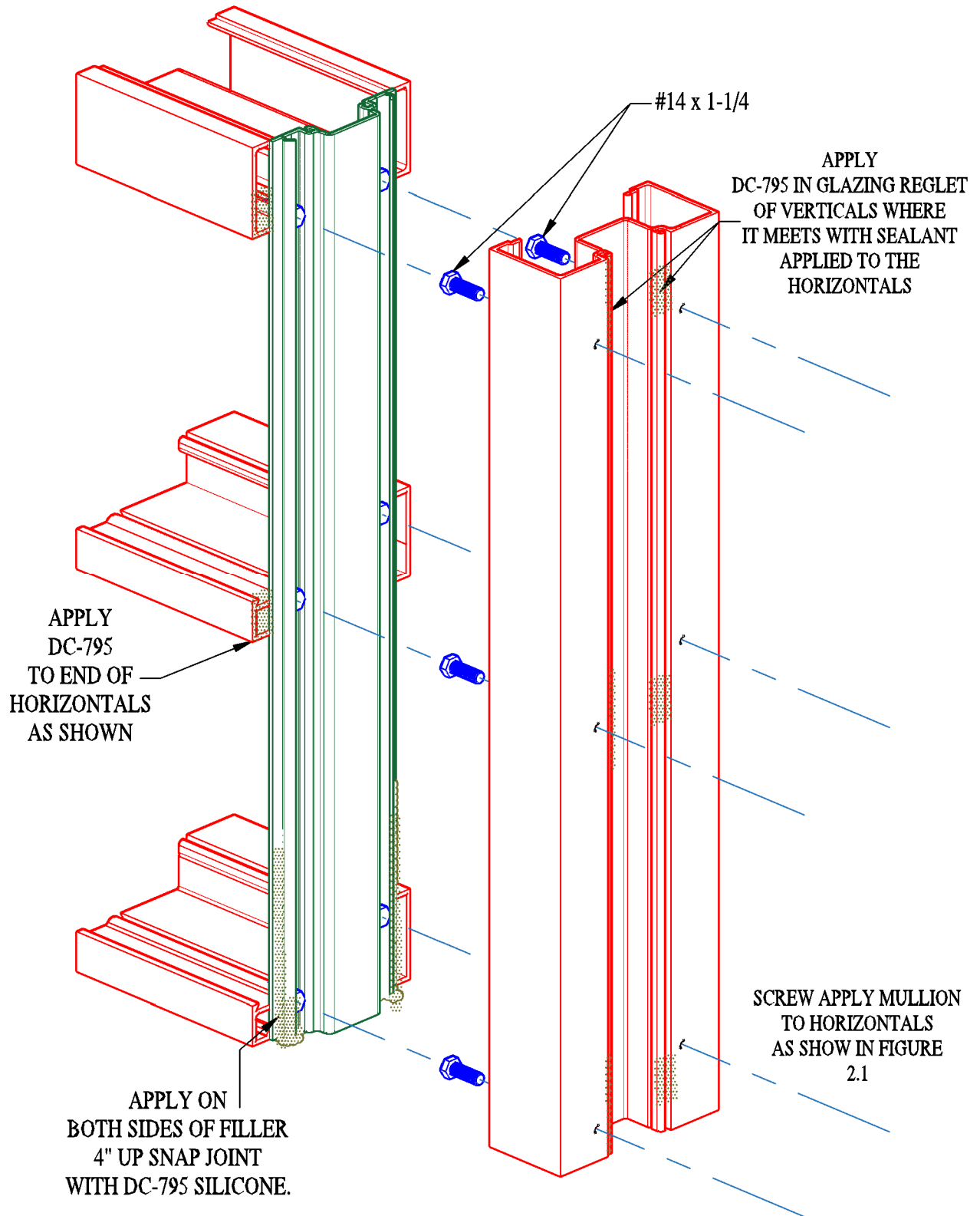

FIGURE 2.2
MULLION
INSTALLATION



ARCHITECTURAL METALS, INC.

PHONE: 713-869-9551

Web Address: www.atlasarchmetals.com

Made In



2000 INSTALLATION MANUAL

GLAZING GUIDELINES

3.1 Glazing guidelines will be as followed after framing system is installed. Prior to sealing corners, clean gaskets and surfaces with Isopopyl Alcohol.

A) Remove gasket from roll and allow to relax overnight. All gaskets to be cut D.L.O. + 1/4" per foot.

B) Vertical gaskets run thru horizontal gaskets. Horizontal gaskets should be mitered on ends as shown in **FIGURE 3.1**.

C) Install exterior gasket prior to glazing. Corners of exterior gaskets to be set in sealant as shown in **FIGURE 3.2** .Corners to be sealed just prior to setting glass as shown in **FIGURE 3.1**.

D) Locate Setting Blocks at either 1/4" or 1/8" points, depending on glass size.

E) Glass bite at typical horizontal & vertical members is 7/16".

F) Glazing openings from bottom to top install water diverters. Install in horizontal above, after lite below is in position.

G) Water diverters must be located on each end of horizontals and set in DOW 295/305

3.2 When installing glass, first wet top of setting block with soapy water. Once glass is set in place, push glass against gasket at setting block area. Failure to do so may cause diagonal cracks towards setting blocks due to glass bending while installing gasket(s) at corners.

2000 INSTALLATION MANUAL

GLAZING GUIDELINES

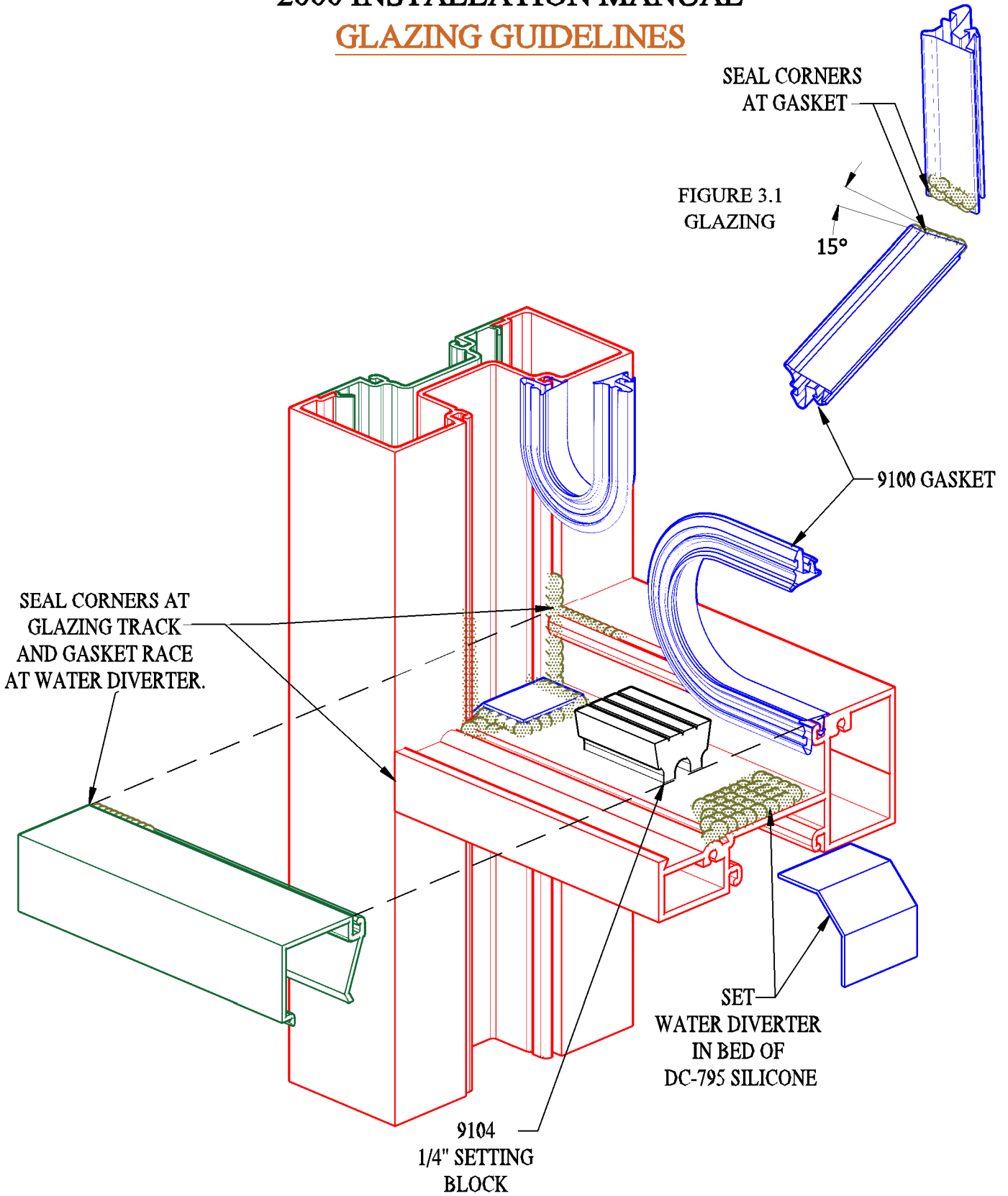

FIGURE 3.2
GLAZING



PHONE: 713-869-9551

Web Address: www.atlasarchmetals.com

Made In
AMERICA